

LAMSYSTEMS

New generation:
PROTECTION AS
AN UNCONDITIONED
REFLEX

Microbiological Safety
CABINETS



Neoteric



PERFECTION INSPIRED BY NATURE

www.lamsys.com



Microbiological Safety CABINET

Class II



Meets the requirements of EN 12469:2000 standard

APPLICATION

The cabinet is designed for physical isolation (containment and controlled removal from the working zone) of pathogenic biological agents (PBA) and microorganisms to prevent airborne infection of the staff and contamination of the air in the working room and to protect the environment, along with protection of the working agents inside the working zone from external and cross-contamination.

FUNCTIONING

The cabinet is used to equip individual working places in virologic and bacteriological laboratories of medical, pharmaceutical and other institutions working with pathogenic agents.



1200 mm →

AIRFLOW LAYOUT

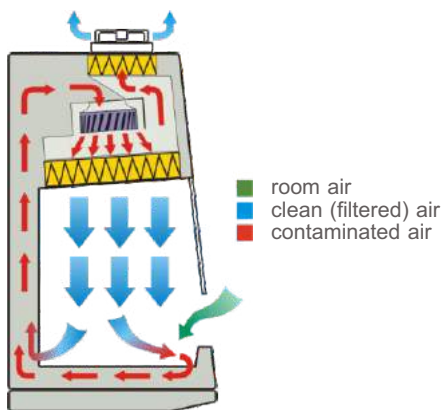

DIMENSIONAL DRAWING

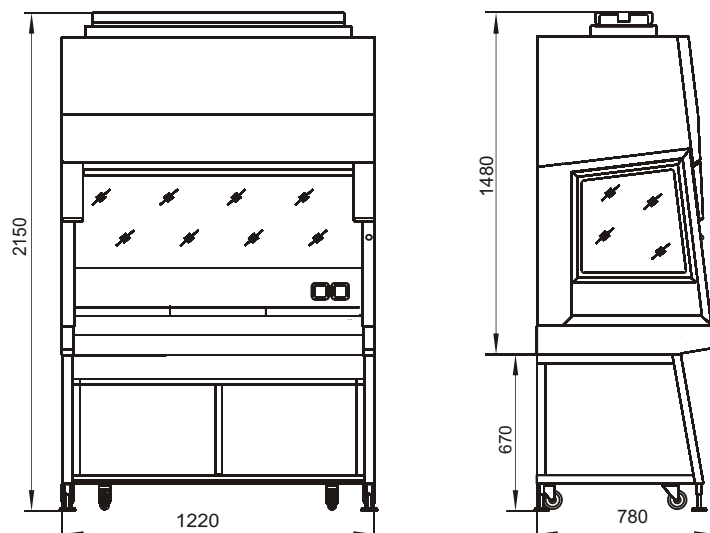



www.lamsys.com

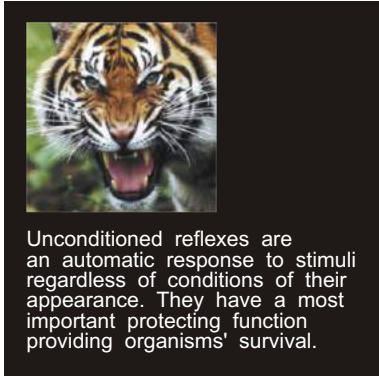

Unconditioned reflexes are an automatic response to stimuli regardless of conditions of their appearance. They have a most important protecting function providing organisms' survival.

Similar to unconditioned reflexes animals have, the audio-visible indication reacts automatically to any changes that reduce protecting properties of the new generation of microbiological safety cabinets.

AUDIBLE-VISIBLE INDICATION REFLEX^{LS}

The air curtain created in the front working opening keeps dangerous microorganisms in the working chamber effectively if only there is air flow continuity throughout the entire front opening.

If the front grille on the table surface is blocked during the working process it breaks the integrity of the air curtain and causes the emission of pathogenic agents into the environment and directly to the operator.

The cabinet is provided with the fast-response audible-visible indication system REFLEX^{LS}, and in case of blocking the front grille, it will immediately warn the operator about worsening of the cabinet protective properties and the emerged danger.

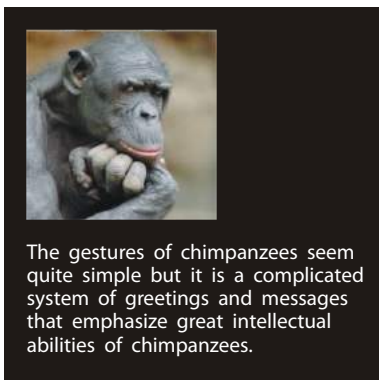

The gestures of chimpanzees seem quite simple but it is a complicated system of greetings and messages that emphasize great intellectual abilities of chimpanzees.

The cabinet is provided with a microprocessor control system which immediately informs the operator about reduction of the protective properties of the cabinet showing an alarm message on the display and activating the audio-visible system.

MICROPROCESSOR CONTROL SYSTEM

The fan motor control system Sintell-1 allows to minimize the power consumption of the cabinet, to reduce the level of acoustic and electromagnetic noise.

The system of air consumption static regulation AIS LS automatically regulates air balance in the working chamber, changing the number of fan revolutions according to the level of filters contamination. Reaching the threshold value of contamination the system activates the warning system.

The system of monitoring the cabinet working modes and the audio-visible indication warns about the airflow imbalance in the working chamber.



THE DISPLAY SHOWS THE FOLLOWING ALARM MESSAGES:

- LAMINAR FLOW FAILURE!
- BLOCKED CABINET AIR GRILLE!
- UV UNIT IS NOT SET ON PLACE!
- FRONT SASH IS OPEN!
- TABLE TOP IS NOT PLACED!
- LOW INFLOW VELOCITY!
- LOW DOWNFLOW VELOCITY!
- HIGH DOWNFLOW VELOCITY!

The unambiguity of these messages hides multifunctioning of the operational system for indicating malfunctions and analyzing causes of their appearance.



www.lamsys.com



Bees keep the unique smell of their hive in a special place on their body which they open and produce to the guards at the hive entrance as if their id or pass.

A no-touch electromagnetic key effectively protects the control system from an unauthorized access.



There is a possibility of buying standard electromagnetic keys and then putting their codes into the control system memory. You can find a detailed instruction in the user manual.

* - the standard delivery set includes 3 keys

UNAUTHORIZED ACCESS PROTECTION

The automatic blocking of control panel buttons excludes the access of unauthorized personnel to the cabinet control. It is only possible to unlock the panel with an electromagnetic key*.

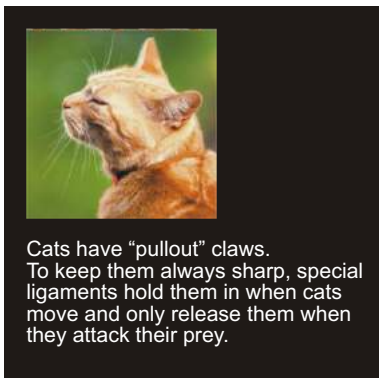

Cats have "pullout" claws. To keep them always sharp, special ligaments hold them in when cats move and only release them when they attack their prey.

The cabinet has a pullout UV unit which is placed at the bottom of the cabinet (outside contamination zone) and only used when it is necessary to make disinfection of the working chamber.

THE DESIGN ADVANTAGES:

1. The UV lamp is located outside the working chamber:
 - It doesn't create barriers to the downward airflow and prevents air swirls (turbulence) and thus cross-contamination of the product;
 - The lamp is protected from accidental damage during loading and irradiation of the chamber.
2. In its working position, the UV unit:
 - completely covers the front opening of the cabinet (see the photo) preventing emission of pathogenic agents into the environment and ensuring the protection of the personnel;
 - is controlled by an optical position sensor to prevent accidental personnel irradiation.
3. **DRIVE-N-ROLL** technology:
 - provides easy sanitation and use of UV unit;
 - guarantees the reliability of the pullout mechanism for the entire service life*;
 - there is no need to find a special place for storage (as in case of removable design).

PULLOUT UV UNIT



* Based on the statistics of customer requests for ten years.





www.lamsys.com

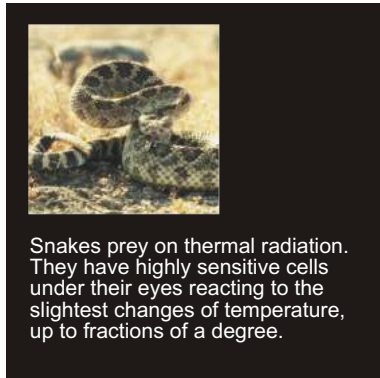

Snakes prey on thermal radiation. They have highly sensitive cells under their eyes reacting to the slightest changes of temperature, up to fractions of a degree.

The position of pullout and movable units influencing the protective properties of the cabinet is controlled by highly sensitive optical sensors.

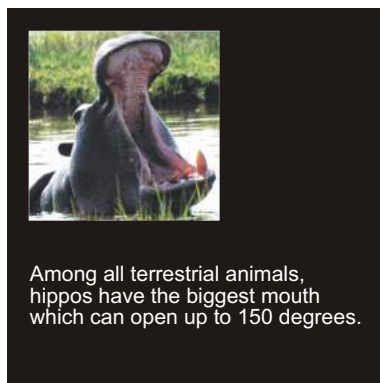

Among all terrestrial animals, hippos have the biggest mouth which can open up to 150 degrees.

The angle of front sash lift is 130 degrees from the vertical that provides for convenience of disinfection and loading of the working chamber.

The sash lifting design was made in accordance with EN 12469:2000. One of the standard requirements to the cabinet design is an easy access to all working surfaces for cleaning and disinfection.

The completely open position of the sash is only used for loading necessary equipment into the cabinet and for the chamber disinfection. In the operation mode the sash is closed.

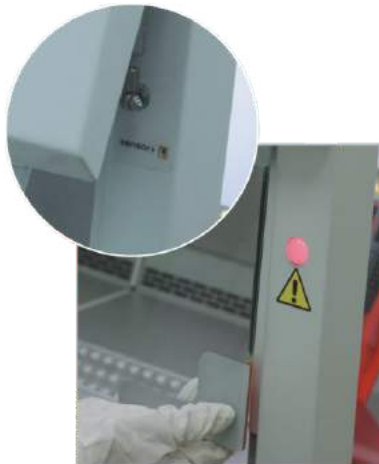

HIGH PRECISION OPTICAL SENSORS

1. The front sash position sensor can detect a gap of only 5 mm.

2. The UV unit position sensor immediately turns off the UV lamp at the attempt of opening the working UV unit, thus preventing accidental personnel irradiation.

SASH-LIFTING MECHANISM – GAS-SPRINGS

Lifting the sash with the help of gas-springs is the absolute advantage to the balance sliding design (where you cannot open the sash completely) as it provides an easy disinfection of the front sash inner surface and it doesn't have any quick wear mechanisms and details such as cables.

The fixed sizes of the front working opening are calculated in accordance with the air flow requirements ensuring the personnel protection.





www.lamsys.com



A woodpecker knocking on a tree with all might could die of brain concussion if it didn't have a strong damper between its beak and brain that distributes and softens the weight of blow.

HYDRAULIC DAMPERS

The cabinet is equipped with hydraulic dampers for smooth closing of the front sash and of the UV unit. This feature eliminates the possibility of damaging the cabinet's parts at abrupt closing and, thus, provides comfortable operation.



Colourful spots on the wings of the Peacock butterflies (*Vanessa io* L.) serve to frighten insect-eating birds as the sight of big bright "eyes" means a signal of danger to them.

FRONT SASH CORNERS MARKING

Coloured marking of the front sash corners in the open position serve as warning and help to prevent accidental injuries of the personnel.



Though it is very thin, an egg shell is far from being fragile. Seven layers and a thin elastic film provide the shell with increased strength and keep its protective properties even at sudden changes of temperature and humidity.

FRONT SASH – LAMINATED GLASS

The laminated glass (triplex) consists of two layers of glass and a polymer film. Because of this, when broken, triplex doesn't form sharp injury-causing fragments, but only gets cracked keeping its form. The front sash damage causes neither disturbance of the air flows nor reduction of the protective properties of the cabinet.



Elephants can stand or walk for long periods of time without tiring. They even sleep on their feet because their stable strong legs support their weight well.

STABLE STRUCTURE

The stable structure of the cabinet is a necessary condition for safe operation. So the platform has screw supports to adjust and fix the mounted cabinet. Caster wheels are only intended for the convenience of moving the cabinet to the place of mounting.

The cabinet passed the stability test according to EN 12469:2000 requirements.



Stability test



www.lamsys.com



Ants have the biggest brain if compared with their bodies among all living beings on Earth.

The cabinet has the largest possible size of the working chamber with minimum external dimensions.

BIG WORKING CHAMBER

Taking into account that laboratories have small size, low ceiling, narrow doors and staircases, the external cabinet dimensions were minimized while preserving the size of the chamber and all the properties of the equipment.



A kangaroo's tail is a reliable support when the animal is sitting. Based on their tail kangaroos rest relaxing the muscles of their hind quarters.

ARM SUPPORT

- Protects from accidental covering of the front table grille;
- Suitable for thorough disinfection and autoclave sterilization;
- Stored in a special compartment of the pullout UV unit.



The movable arm support provides a reliable rest for an operator's elbows; it prevents from keeping his arms hanging at all times and creates additional comfort at work.





www.lamsys.com

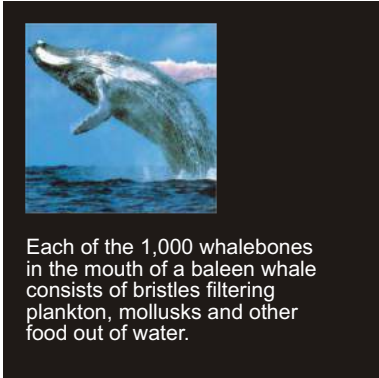

Each of the 1,000 whalebones in the mouth of a baleen whale consists of bristles filtering plankton, mollusks and other food out of water.

The cabinet is equipped with a HEPA filter providing air purification efficiency of 99.995% for 0.3 µm particles.



Each HEPA filter is tested and packed in conformity with American standard IEST-RP-CC-001.3 (HEPA and ULPA) or European standard EN 1822.

The filter efficiency is tested by an aerosol test on a special stand by scanning the clean side of the filter and counting infiltrated particles.

PANEL FINE FILTERS

The HEPA filter is placed at the entrance to the working chamber at the angle of 7° to the horizontal and thus at the right angle to the front sash.

Such position considerably improves the air flow in the chamber.

The filter is fixed with springs ensuring leak-tight seal of the filter for the entire lifetime.

The microprocessor control system monitors the degree of the filter contamination each time the cabinet is switched on, and if the critical level is reached (≈90%) it shows the information on the LCD display.

MAIN TECHNICAL CHARACTERISTICS:

Filter class	H14
Retention at MPPS, %	99,995
Minimum service life, years	4*

**provided the cabinet is operated in accordance with the requirements of the Manual*

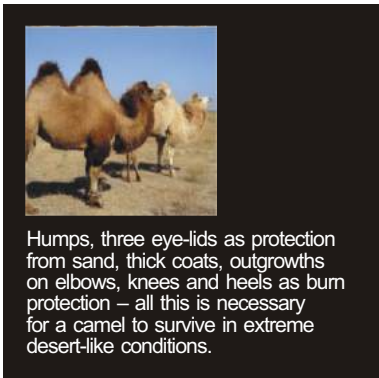

Humps, three eye-lids as protection from sand, thick coats, outgrowths on elbows, knees and heels as burn protection – all this is necessary for a camel to survive in extreme desert-like conditions.

Additional options can adapt the cabinet to various service conditions and extend the range of tasks solved.



ADDITIONAL OPTIONS

– A hood to connect the cabinet to an external exhaust system.



– Extra sockets.



– A gas tap with an electromagnetic valve*.

– A vacuum tap with an electromagnetic valve*.

A gas tap and a vacuum tap can be installed in a functional cabinet without any additional validation.

* The electromagnetic valve automatically closes gas and vacuum supply when the power is down or the cabinet is turned off.

ACCEPTANCE TEST



www.lamsys.com



THE ACCEPTANCE TESTING AREA

is made on the “clean room” basis and provided with certified equipment to carry out necessary testing of all commercial products.

Acceptance test of the **Neoteric** cabinet consists of 23 obligatory checks whose results are formally reported. A test report copy can be provided as per customer’s request.



GENERAL TECHNICAL CONDITION

Design integrity and functionality and conformity with the cabinet marking are checked.



INFLOW AND DOWNFLOW PARAMETERS

After appropriate adjustment the following velocity is set up:
for inflow through the work opening – 0.47m/s,
for downflow in the working chamber – 0.35 m/s (in accordance with EN 12469:2000).

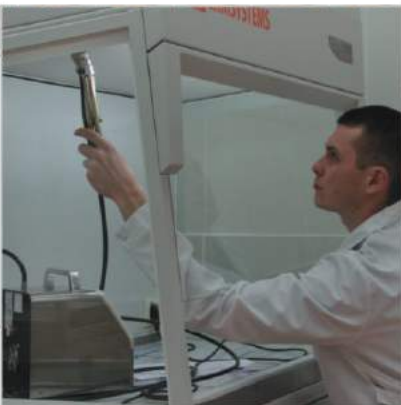

HEPA FILTER INTEGRITY CHECKING

The supply and exhaust filters and their sealing are checked.



AUDIO-VISIBLE INDICATION ADJUSTMENT

Alarm thresholds are adjusted for:
– inflow and downflow velocity;
– front sash opening in the Operation mode;



- front table air grille blocking;
- incorrect installation of the tabletop sections;
- pulling out of the UV unit in Storage mode.



AUDIBLE-VISIBLE INDICATION

Alarm indication is switched on automatically when the air flow parameters are deviated from the specified.*



CABINET MATERIALS

Housing – powder coated metal, corrosion-resistant, non-flammable, non-absorbing.
Table top – stainless steel.
Glass – laminated glass (front), tempered glass (side).**



HOUSING LEAK TIGHTNESS

Checked by creating internal pressure after sealing all openings and by carrying out a soap bubble test for all joints, junctions and gaskets.



NOISE

The noise level meets the requirements of EN 12469:2000 standard.



ILLUMINATION

Illumination corresponds to the conditions of safe operation in the cabinet working zone. The working surface illuminance is 1,000 lux while recommended one is 750 lux.

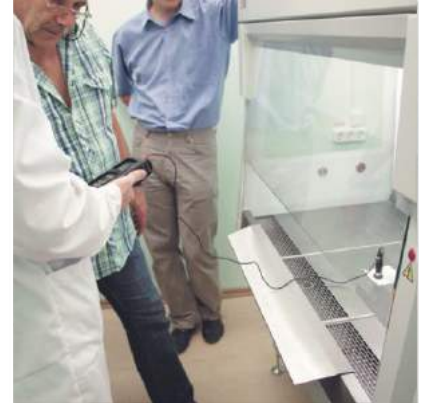

VIBRATION

The vibration mean-square displacement value in the table top centre of the operating cabinet does not exceed 0.005 mm (frequency range of 20–20000 Hz).

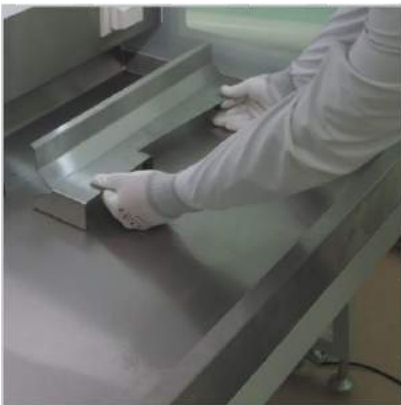

SUITABILITY FOR CLEANING AND DISINFECTION

The cabinet design allows an easy access to all surfaces that come in contact with pathogenic agents and microorganisms and their disinfection. The arm support and each segment of the movable table top can be sterilized in an autoclave. The corners of the tray are rounded for a more convenient and better treatment.



FORMALDEHYDE AND AMMONIA TREATMENT (FUMIGATION)

The cabinet is well adapted to fumigation. A simplified method of formaldehyde disinfection is described in detail in the user manual.

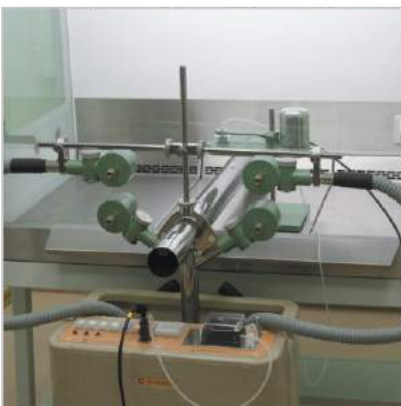

KI DISCUS TEST

Tests for pathogenic agents retention efficiency in the front opening.

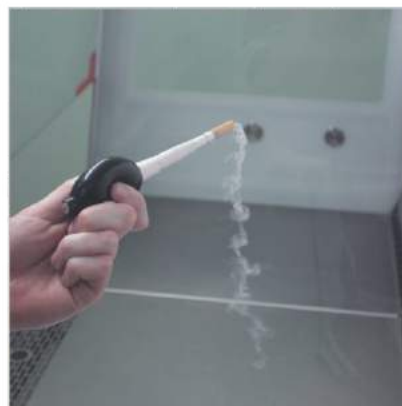

Video
"Airflow visualization"

AIR FLOW VISUALIZATION

Shows the proper distribution and directions of airflow at different points of the working chamber and throughout the front working opening.

* For a period of warming up and preparing the cabinet for the main operation mode the audio indication can be switched off manually.

** All materials are resistant to cleaning agents and disinfectants as well as formaldehyde processing.

IMPORTANT! WHEN USING CHLORINE COMPOUNDS REMEMBER OF THEIR CORROSIVE PROPERTIES INCLUDING THE IMPACT ON STAINLESS STEEL.



Personnel Protection



Environment Protection



Product Protection

LAMSYSTEMS

Neoteric



MAIN CHARACTERISTICS

Installation work chamber air cleanliness class for suspended particle (aerosol) concentration as per ISO 14644-1:2015

– for particles of 0.5µm and more.....	ISO 5
– for particles of 5.0µm and more.....	ISO M (20; ≥5µm); LSAPC
Cabinet class according to EN 12469:2000, NSF/ANSI 49	II
Class of HEPA filters as per EN 1822-1.....	H14
Average velocity of the inflow through the work opening, m/s.....	0,47±0,03
Average downflow velocity in the work chamber, m/s.....	0,35±0,01
Air recirculation, %.....	≈ 70

MAIN PARAMETERS AND DIMENSIONS

Article.....	2E-B.001-12
Maximum dimensions of the cabinet with stand* (WxDxH), mm.....	1200x770x2150*
Dimensions of the work chamber (WxDxH), mm.....	1105x610x750
Rated input power** (without built-in electric sockets), W.....	110**
Maximum allowed load on the built-in electric sockets, W.....	1000
Downflow, m ³ /h.....	795-817
Inflow, m ³ /h.....	333-378
Illumination of the work zone, lx.....	1000
Maximum net weight of the cabinet with stand, kg.....	230
Maximum noise level at 1 m distance from the cabinet, dB(A).....	55***

* Dimensions do not account for outstanding supports
(The supports stand out of the cabinet's dimensions by 10 mm on each side).

** Power when HEPA filters are new (not clogged).

*** Level of noise at Main Operation mode measured as per DIN EN ISO 11201:2010 in free sound field over the sound-reflecting surface (noise level in real operating environment depends on the dimensions of the operating site as well as and on the total background noise and may vary by 3-4 dB(A)). Indeterminacy: k = 2 dB(A).

ADDITIONAL OPTIONS

- Multi-purpose taps
- Extra outlets
- ULPA filters
- LED lighting of the working chamber
- Hood to connect the cabinet to external exhaust system

A complete list of additional options to each cabinet is available at our website www.lamsys.com

PERFECTION INSPIRED BY NATURE

www.lamsys.com



LAMSYSTEMS

LAMSYSTEMS CC
Turgoyak Road, 2/4
Miass, Chelyabinsk region
456313 Russia
Tel./fax: +7-3513-255-255
sales@lamsys.com

LAMSYSTEMS GmbH
Magdeburger Str. 3
14641 Wustermark bei Berlin
Germany
Tel.: +49 (0) 30 2555 9888
info@lamsys.com

Published in 2022.
Manufacturer reserves its right to change technical specification and configuration of the equipment in the course of its further development.